

Operating Temperature: 0°C~70°C
 Operating Humidity: 20%~80% (no condensation)
 Storage Temperature: -25°C~85°C
 Storage Humidity: 20%~80% (no condensation)

L:
 CBL-PD302MBS-1m 1000mm±10mm
 CBL-PD302MBS-2m 2000mm±20mm
 CBL-PD302MBS-3m 3000mm±20mm

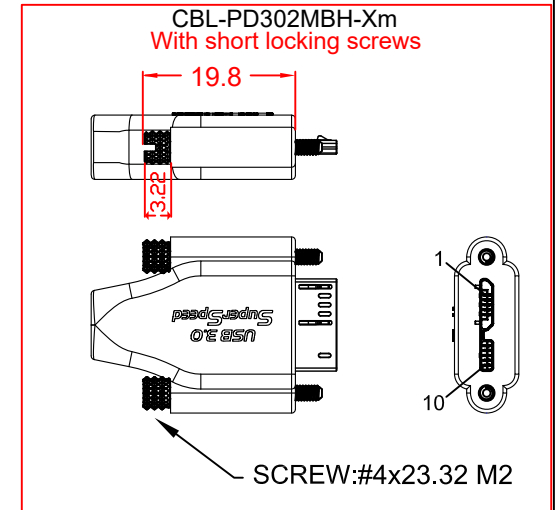
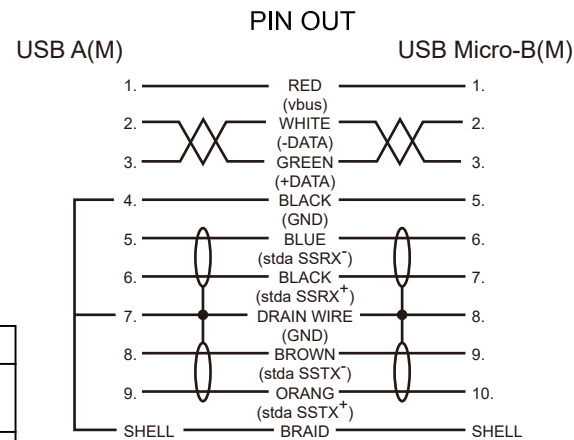

No	MATERIALS LIST:
1.	CABLE:UL2725 (28AWG*1PR+D+AM)x2C+28AWG*1PR+24AWG*1C+AM+B OD:5.6mm PVC JACKET COLOR:BLACK
2.	CONNECTOR:USB 3.0 A/M, 9P, BLUE INSULATOR SOLDER TYPE, NICKEL PLATED SHELL
3.	CONNECTOR:USB 3.0 MicroB/M, 10P, BLACK INSULATOR SOLDER TYPE, NICKEL PLATED SHELL
4.	PVC MOLDED HOUSING, BLACK COLOR
5.	SCREW:#4x33 M2

Jargy part no.	Client part no.	Approved	SCALE	UNIT
CBL-PD302MBS-Xm				mm
Drawing Name		Drawn	Date	REV.
USB 3.0 A to MicroB Cable M/M				1.0

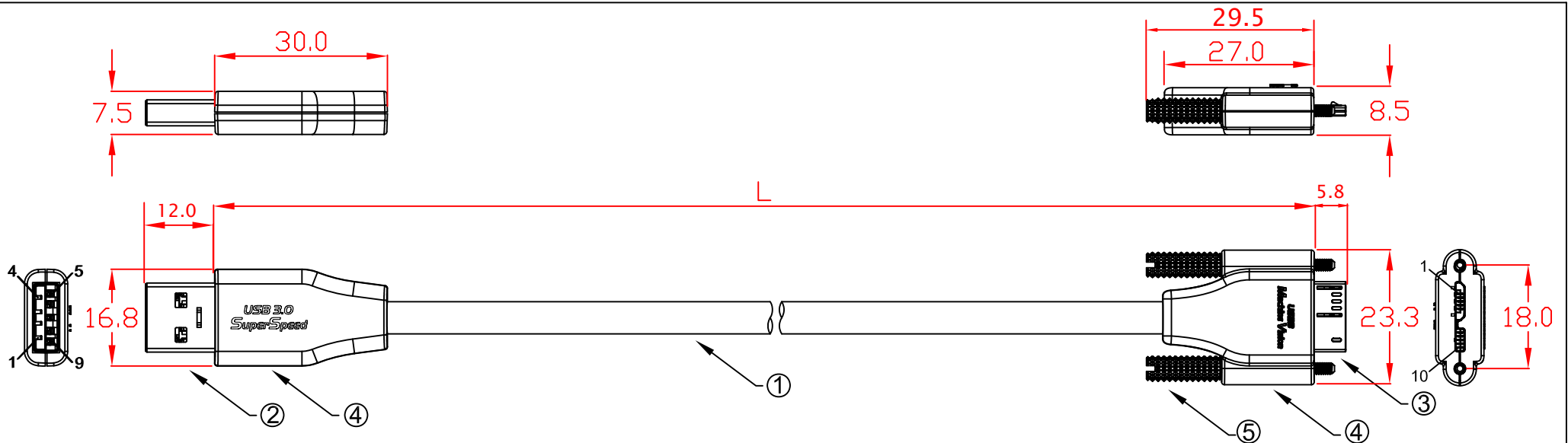

Operating Temperature: 0°C~70°C
 Operating Humidity: 20%~80% (no condensation)
 Storage Temperature: -25°C~85°C
 Storage Humidity: 20%~80% (no condensation)

L:
 CBL-PD302MBS-1m 1000mm±10mm
 CBL-PD302MBS-2m 2000mm±20mm
 CBL-PD302MBS-3m 3000mm±20mm

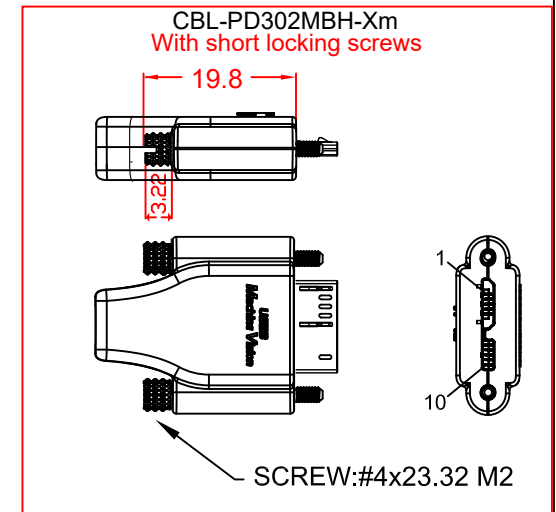
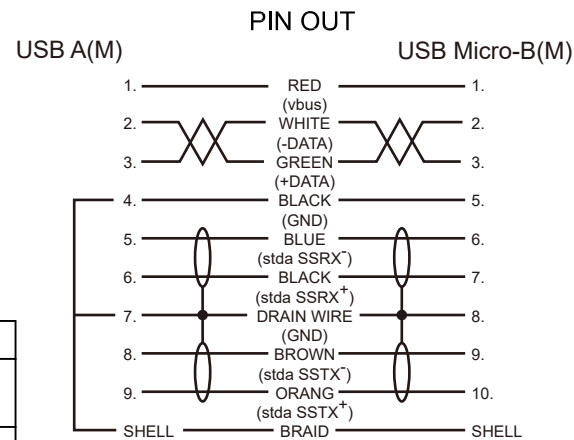

No	MATERIALS LIST:
1.	CABLE:UL2725 (28AWG*1PR+D+AM)x2C+28AWG*1PR+24AWG*1C+AM+B OD:5.6mm PVC JACKET COLOR:BLACK
2.	CONNECTOR:USB 3.0 A/M, 9P, BLUE INSULATOR SOLDER TYPE, NICKEL PLATED SHELL
3.	CONNECTOR:USB 3.0 MicroB/M, 10P, BLACK INSULATOR SOLDER TYPE, NICKEL PLATED SHELL
4.	ABS HOUSING, BLACK COLOR
5.	SCREW:#4x33 M2

Jargy part no.	Client part no.	Approved	SCALE	UNIT
CBL-PD302MBS-Xm				mm
Drawing Name		Drawn	Date	REV.
USB 3.0 A to MicroB Cable M/M				1.0

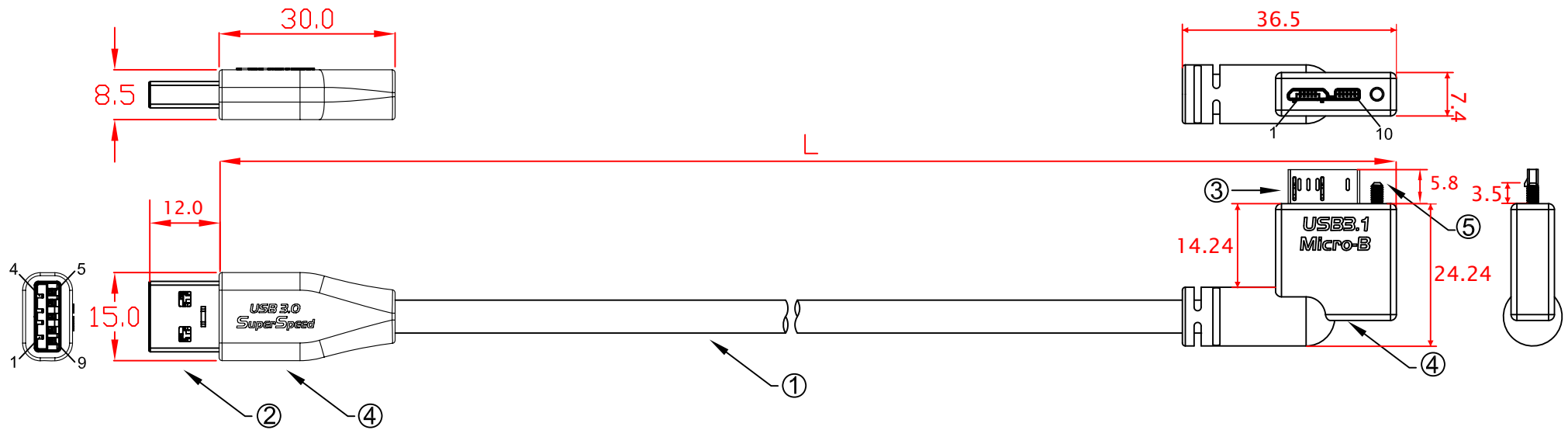

Operating Temperature: 0°C~70°C
 Operating Humidity: 20%~80% (no condensation)
 Storage Temperature: -25°C~85°C
 Storage Humidity: 20%~80% (no condensation)

L:
 CBL-PD302MBHM-1mLA 1000mm±10mm
 CBL-PD302MBHM-2mLA 2000mm±20mm
 CBL-PD302MBHM-3mLA 3000mm±20mm

No	MATERIALS LIST:
1.	CABLE:UL2725 (28AWG*1PR+D+AM)x2C+28AWG*1PR+24AWG*1C+AM+B OD:5.6mm PVC JACKET COLOR:BLACK
2.	CONNECTOR:USB 3.0 A/M, 9P, BLUE INSULATOR SOLDER TYPE, NICKEL PLATED SHELL
3.	CONNECTOR:USB 3.0 MicroB/M, 10P, BLACK INSULATOR SOLDER TYPE, NICKEL PLATED SHELL
4.	PVC MOLDED HOUSING, BLACK COLOR
5.	SCREW:#4x23.32 M2
6.	

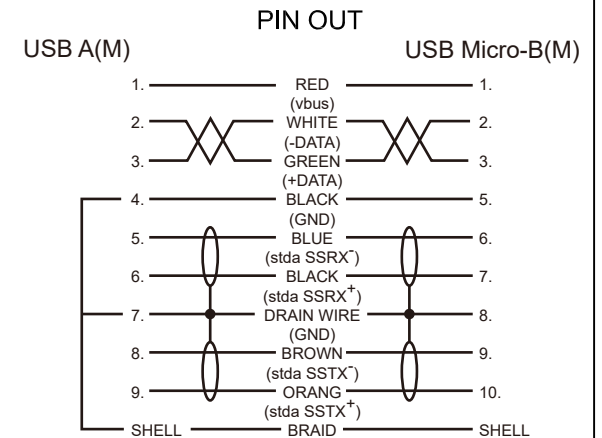

Jargy part no.	Client part no.	Approved	SCALE	UNIT
CBL-PD302MBHM-xmLA				mm
Drawing Name		Drawn	Date	REV.
USB 3.0 A to MicroB Cable M/M				1.0

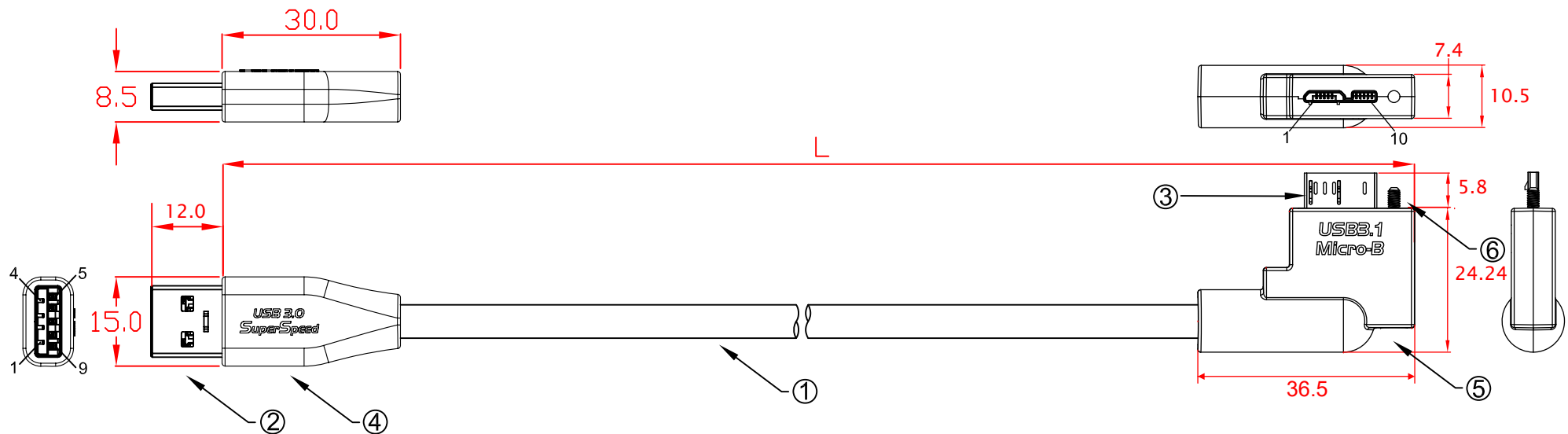

Operating Temperature: 0°C~70°C
 Operating Humidity: 20%~80% (no condensation)
 Storage Temperature: -25°C~85°C
 Storage Humidity: 20%~80% (no condensation)

L:
 CBL-PD302MBSN-1mLA 1000mm±10mm
 CBL-PD302MBSN-2mLA 2000mm±20mm
 CBL-PD302MBSN-3mLA 3000mm±20mm

No	MATERIALS LIST:
1.	CABLE:UL2725 (28AWG*1PR+D+AM)x2C+28AWG*1PR+24AWG*1C+AM+B OD:5.6mm PVC JACKET COLOR:BLACK
2.	CONNECTOR:USB 3.0 A/M, 9P, BLUE INSULATOR SOLDER TYPE, NICKEL PLATED SHELL
3.	CONNECTOR:USB 3.0 MicroB/M, 10P, BLACK INSULATOR SOLDER TYPE, NICKEL PLATED SHELL
4.	PVC MOLDED HOUSING, BLACK COLOR
5.	ABS ASSEMBLY HOUSING, BLACK COLOR
6.	SCREW:#4x23.32 M2

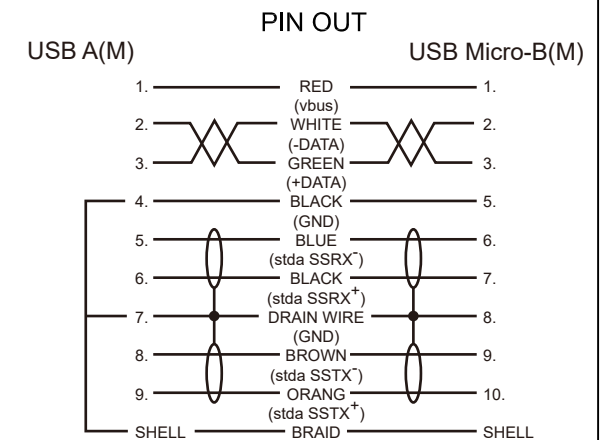

Jargy part no.	Client part no.	Approved	SCALE	UNIT
CBL-PD302MBSN-xmLA				mm
Drawing Name		Drawn	Date	REV.
USB 3.0 A to MicroB Cable M/M				1.0

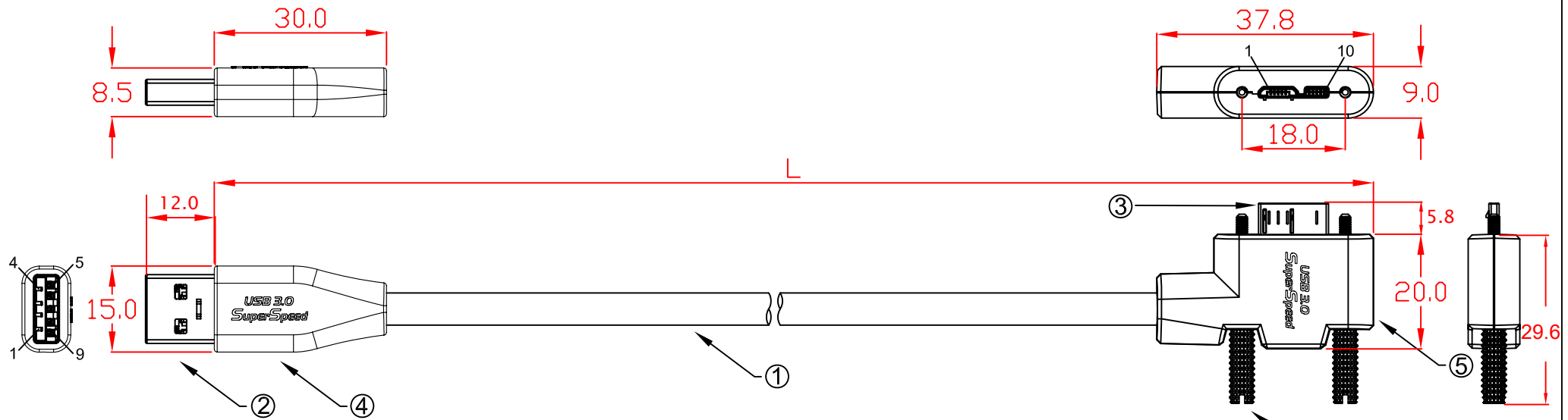

Operating Temperature: 0°C~70°C
 Operating Humidity: 20%~80% (no condensation)
 Storage Temperature: -25°C~85°C
 Storage Humidity: 20%~80% (no condensation)

L:
 CBL-PD302MBS-1mLA 1000mm±10mm
 CBL-PD302MBS-2mLA 2000mm±20mm
 CBL-PD302MBS-3mLA 3000mm±20mm

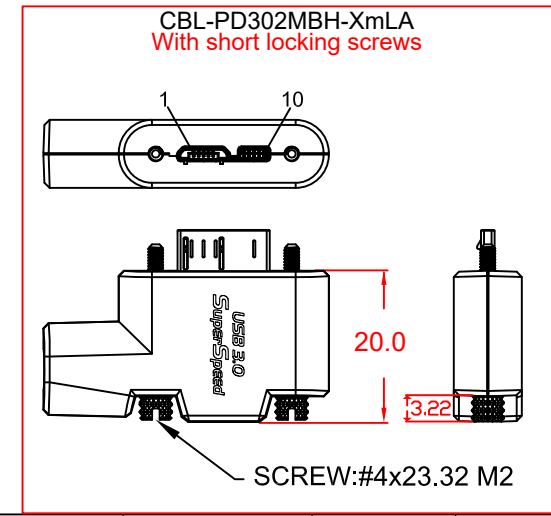
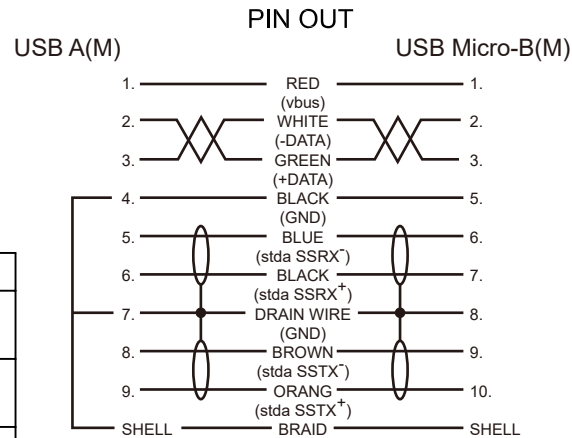

No	MATERIALS LIST:
1.	CABLE:UL2725 (28AWG*1PR+D+AM)x2C+28AWG*1PR+24AWG*1C+AM+B OD:5.6mm PVC JACKET COLOR:BLACK
2.	CONNECTOR:USB 3.0 A/M, 9P, BLUE INSULATOR SOLDER TYPE, NICKEL PLATED SHELL
3.	CONNECTOR:USB 3.0 MicroB/M, 10P, BLACK INSULATOR SOLDER TYPE, NICKEL PLATED SHELL
4.	PVC MOLDED HOUSING, BLACK COLOR
5.	ABS ASSEMBLY HOUSING, BLACK COLOR
6.	SCREW:#4x33 M2

Jargy part no.	Client part no.	Approved	SCALE	UNIT
CBL-PD302MBS-XmLA				mm
Drawing Name		Drawn	Date	REV.
USB 3.0 A to MicroB Cable M/M				1.0

Mobile Computing JARGY

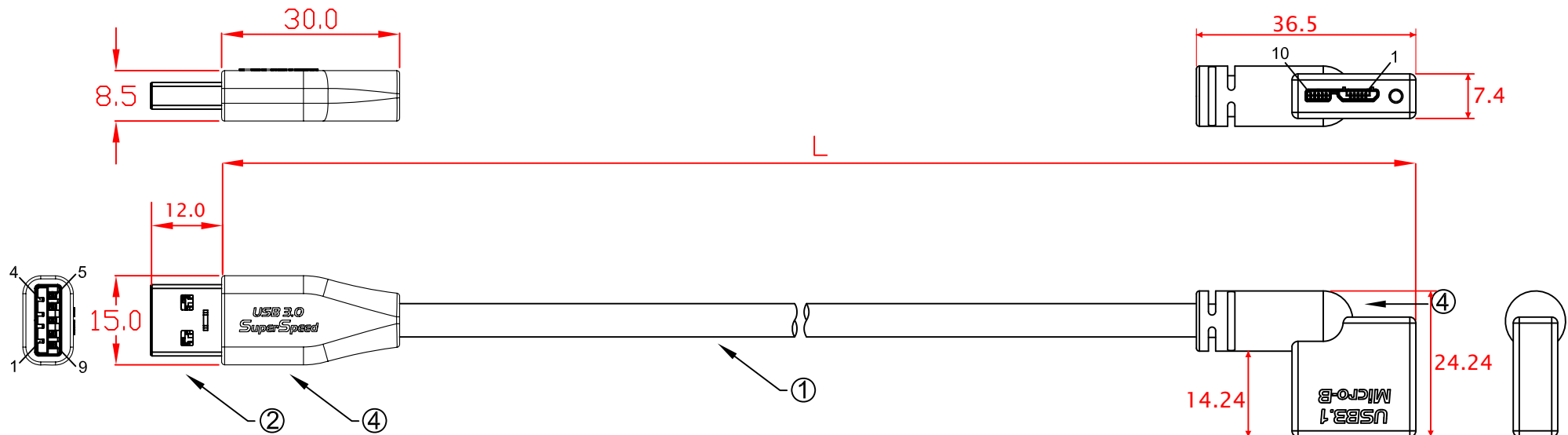

Operating Temperature: 0°C~70°C
 Operating Humidity: 20%~80% (no condensation)
 Storage Temperature: -25°C~85°C
 Storage Humidity: 20%~80% (no condensation)

L:
 CBL-PD302MBHM-1mRA 1000mm±10mm
 CBL-PD302MBHM-2mRA 2000mm±20mm
 CBL-PD302MBHM-3mRA 3000mm±20mm

No	MATERIALS LIST:
1.	CABLE:UL2725 (28AWG*1PR+D+AM)x2C+28AWG*1PR+24AWG*1C+AM+B OD:5.6mm PVC JACKET COLOR:BLACK
2.	CONNECTOR:USB 3.0 A/M, 9P, BLUE INSULATOR SOLDER TYPE, NICKEL PLATED SHELL
3.	CONNECTOR:USB 3.0 MicroB/M, 10P, BLACK INSULATOR SOLDER TYPE, NICKEL PLATED SHELL
4.	PVC MOLDED HOUSING, BLACK COLOR
5.	SCREW:#4x23.32 M2
6.	

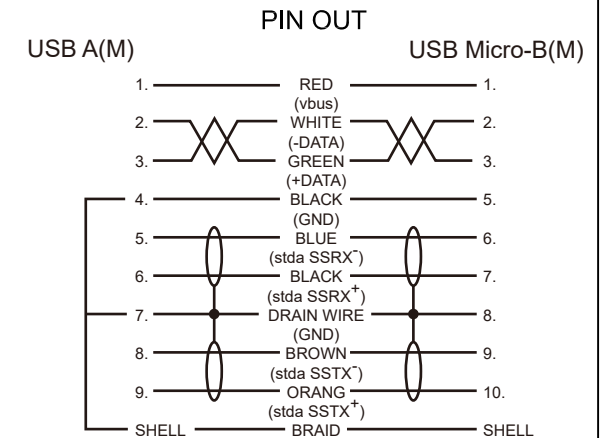

Jargy part no.	Client part no.	Approved	SCALE	UNIT
CBL-PD302MBHM-xmRA				mm
Drawing Name		Drawn	Date	REV.
USB 3.0 A to MicroB Cable M/M				1.0

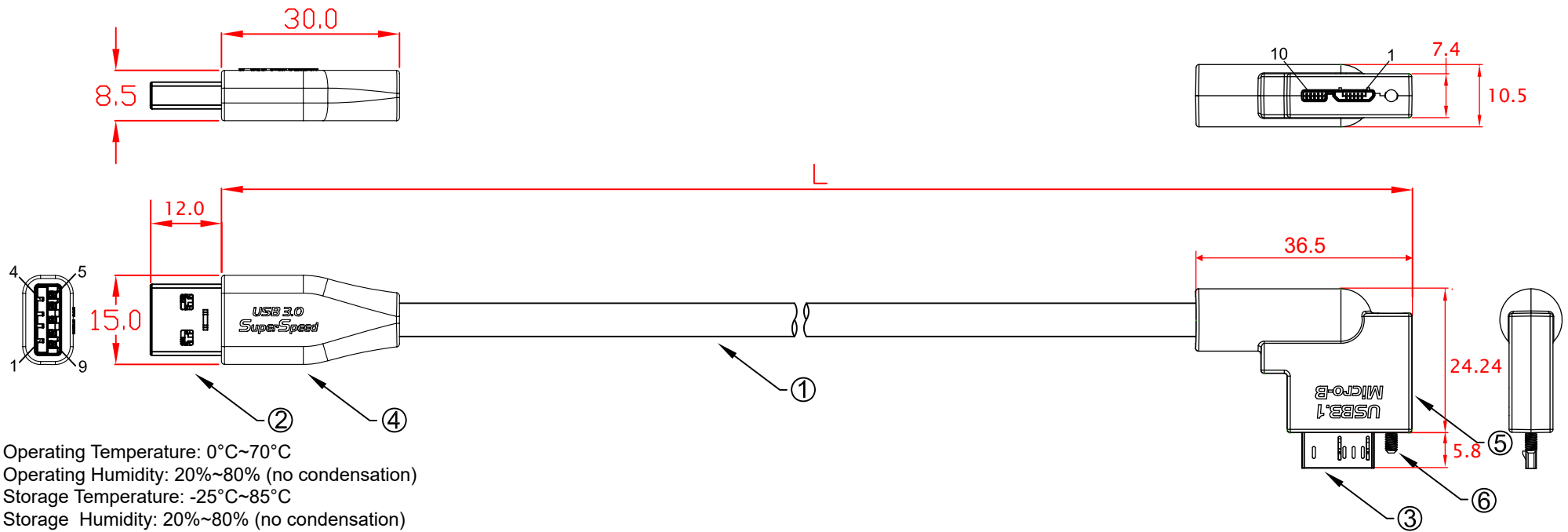

Operating Temperature: 0°C~70°C
 Operating Humidity: 20%~80% (no condensation)
 Storage Temperature: -25°C~85°C
 Storage Humidity: 20%~80% (no condensation)

L:
 CBL-PD302MBSN-1mRA 1000mm±10mm
 CBL-PD302MBSN-2mRA 2000mm±20mm
 CBL-PD302MBSN-3mRA 3000mm±20mm

No	MATERIALS LIST:
1.	CABLE:UL2725 (28AWG*1PR+D+AM)x2C+28AWG*1PR+24AWG*1C+AM+B OD:5.6mm PVC JACKET COLOR:BLACK
2.	CONNECTOR:USB 3.0 A/M, 9P, BLUE INSULATOR SOLDER TYPE, NICKEL PLATED SHELL
3.	CONNECTOR:USB 3.0 MicroB/M, 10P, BLACK INSULATOR SOLDER TYPE, NICKEL PLATED SHELL
4.	PVC MOLDED HOUSING, BLACK COLOR
5.	ABS ASSEMBLY HOUSING, BLACK COLOR
6.	SCREW:#4x23.32 M2

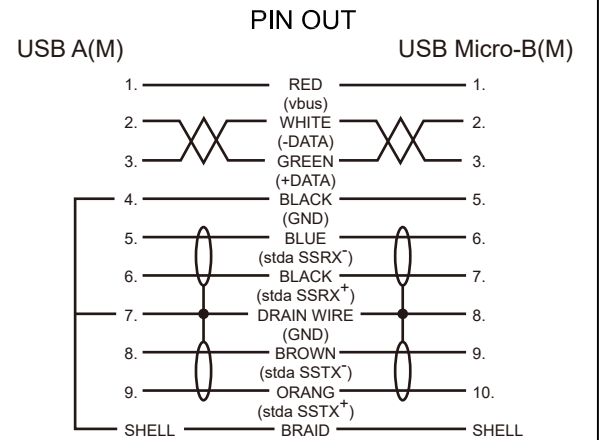

Jargy part no.	Client part no.	Approved	SCALE	UNIT
CBL-PD302MBSN-xmRA				mm
Drawing Name		Drawn	Date	REV.
USB 3.0 A to MicroB Cable M/M				1.0

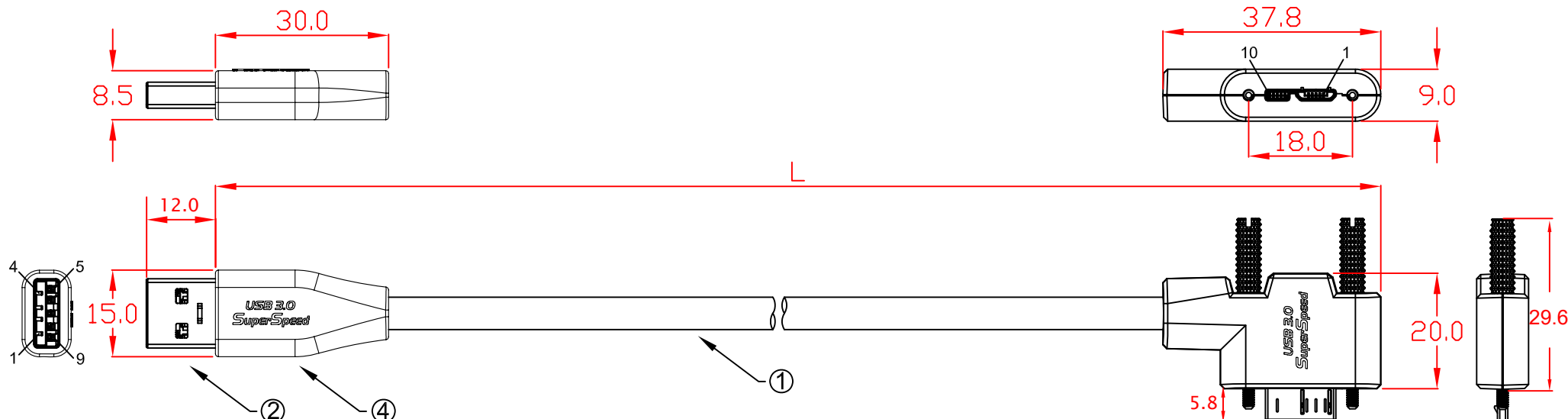

Operating Temperature: 0°C~70°C
 Operating Humidity: 20%~80% (no condensation)
 Storage Temperature: -25°C~85°C
 Storage Humidity: 20%~80% (no condensation)

L:
 CBL-PD302MBS-1mRA 1000mm±10mm
 CBL-PD302MBS-2mRA 2000mm±20mm
 CBL-PD302MBS-3mRA 3000mm±20mm

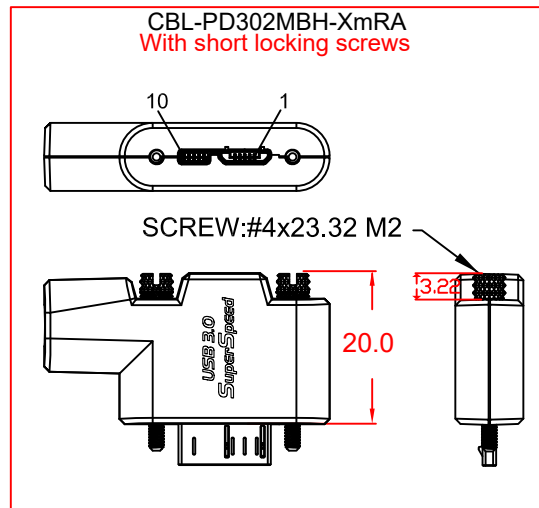
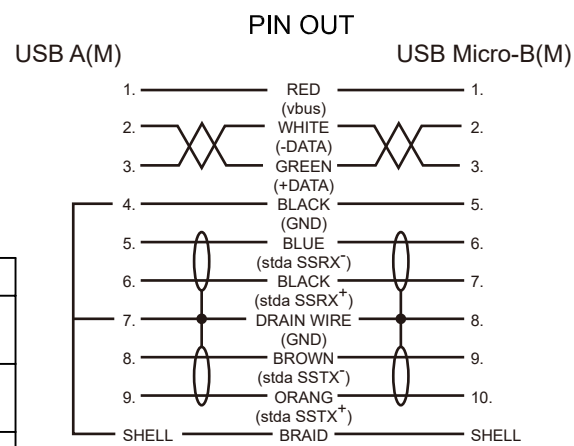

No	MATERIALS LIST:
1.	CABLE:UL2725 (28AWG*1PR+D+AM)x2C+28AWG*1PR+24AWG*1C+AM+B OD:5.6mm PVC JACKET COLOR:BLACK
2.	CONNECTOR:USB 3.0 A/M, 9P, BLUE INSULATOR SOLDER TYPE, NICKEL PLATED SHELL
3.	CONNECTOR:USB 3.0 MicroB/M, 10P, BLACK INSULATOR SOLDER TYPE, NICKEL PLATED SHELL
4.	PVC MOLDED HOUSING, BLACK COLOR
5.	ABS ASSEMBLY HOUSING, BLACK COLOR
6.	SCREW:#4x33 M2

Jargy part no.	Client part no.	Approved	SCALE	UNIT
CBL-PD302MBS-XmRA				mm
Drawing Name		Drawn	Date	REV.
USB 3.0 A to MicroB Cable M/M				1.0

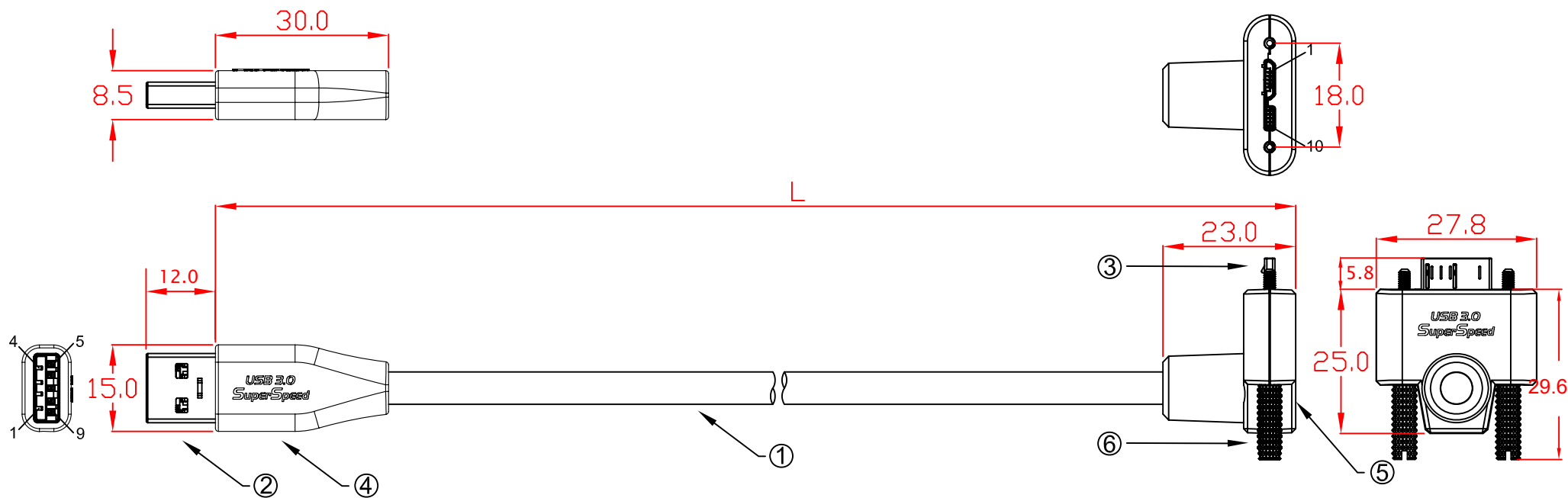

Operating Temperature: 0°C~70°C
 Operating Humidity: 20%~80% (no condensation)
 Storage Temperature: -25°C~85°C
 Storage Humidity: 20%~80% (no condensation)

L:
 CBL-PD302MBS-1mUA 1000mm±10mm
 CBL-PD302MBS-2mUA 2000mm±20mm
 CBL-PD302MBS-3mUA 3000mm±20mm

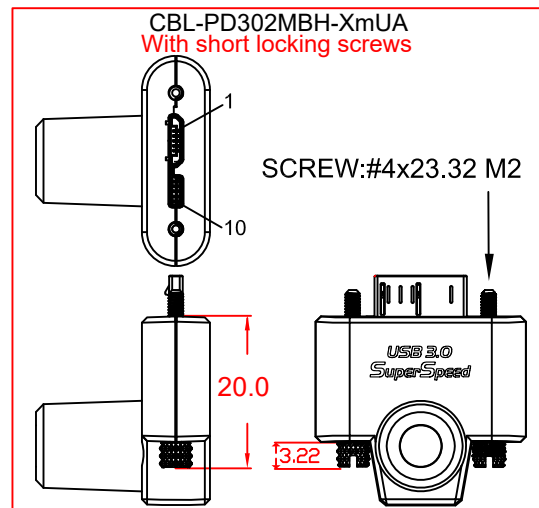
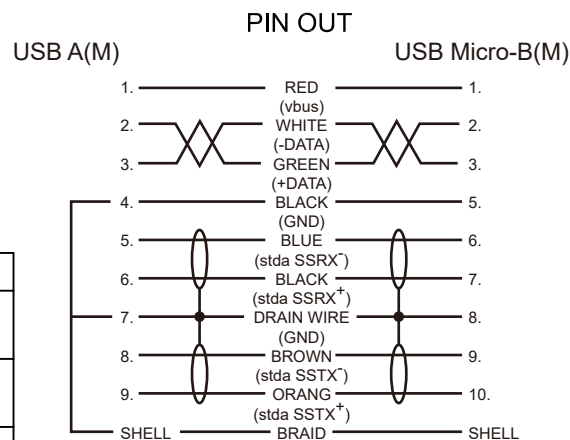

No	MATERIALS LIST:
1.	CABLE:UL2725 (28AWG*1PR+D+AM)x2C+28AWG*1PR+24AWG*1C+AM+B OD:5.6mm PVC JACKET COLOR:BLACK
2.	CONNECTOR:USB 3.0 A/M, 9P, BLUE INSULATOR SOLDER TYPE, NICKEL PLATED SHELL
3.	CONNECTOR:USB 3.0 MicroB/M, 10P, BLACK INSULATOR SOLDER TYPE, NICKEL PLATED SHELL
4.	PVC MOLDED HOUSING, BLACK COLOR
5.	ABS ASSEMBLY HOUSING, BLACK COLOR
6.	SCREW:#4x33 M2

Jargy part no.	Client part no.	Approved	SCALE	UNIT
CBL-PD302MBS-XmUA				mm
Drawing Name		Drawn	Date	REV.
USB 3.0 A to MicroB Cable M/M				1.0

Mobile Computing JARGY

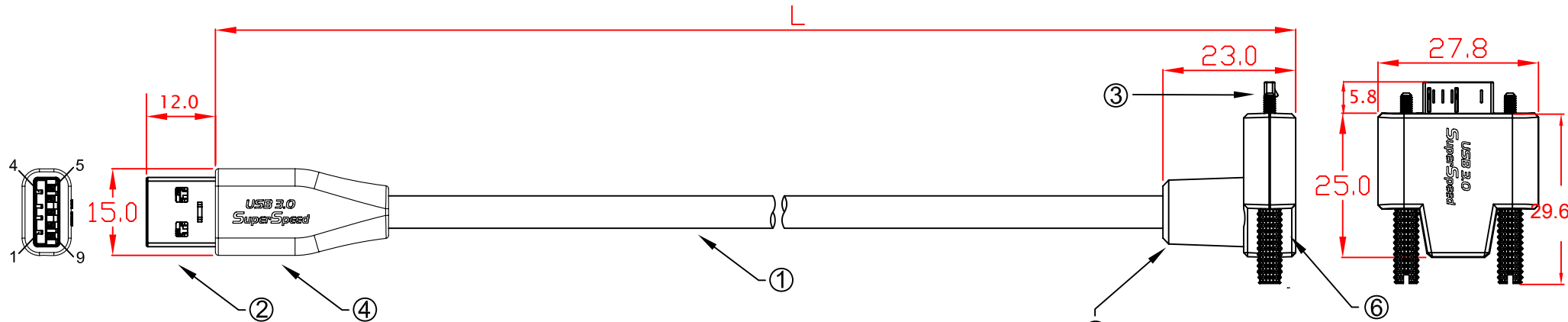
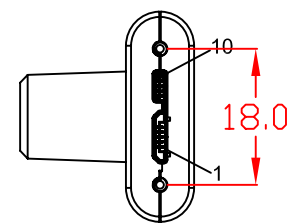
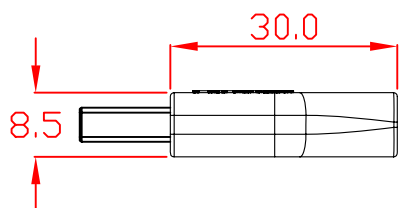

Operating Temperature: 0°C~70°C
 Operating Humidity: 20%~80% (no condensation)
 Storage Temperature: -25°C~85°C
 Storage Humidity: 20%~80% (no condensation)

L:
 CBL-PD302MBS-1mDA 1000mm±10mm
 CBL-PD302MBS-2mDA 2000mm±20mm
 CBL-PD302MBS-3mDA 3000mm±20mm

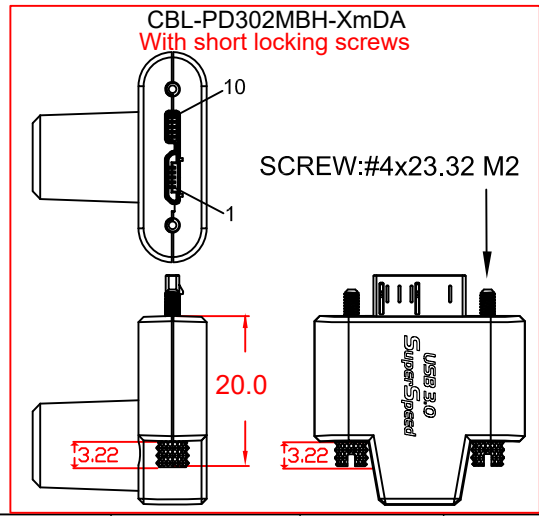
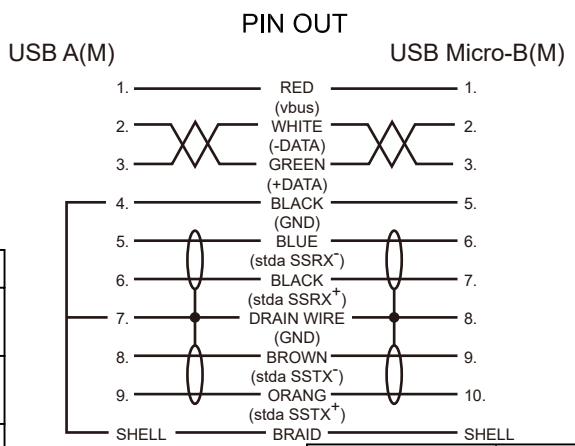

No	MATERIALS LIST:
1.	CABLE:UL2725 (28AWG*1PR+D+AM)x2C+28AWG*1PR+24AWG*1C+AM+B OD:5.6mm PVC JACKET COLOR:BLACK
2.	CONNECTOR:USB 3.0 A/M, 9P, BLUE INSULATOR SOLDER TYPE, NICKEL PLATED SHELL
3.	CONNECTOR:USB 3.0 MicroB/M, 10P, BLACK INSULATOR SOLDER TYPE, NICKEL PLATED SHELL
4.	PVC MOLDED HOUSING, BLACK COLOR
5.	ABS ASSEMBLY HOUSING, BLACK COLOR
6.	SCREW:#4x33 M2

Jargy part no.	Client part no.	Approved	SCALE	UNIT
CBL-PD302MBS-XmDA				mm
Drawing Name		Drawn	Date	REV.
USB 3.0 A to MicroB Cable M/M				1.0

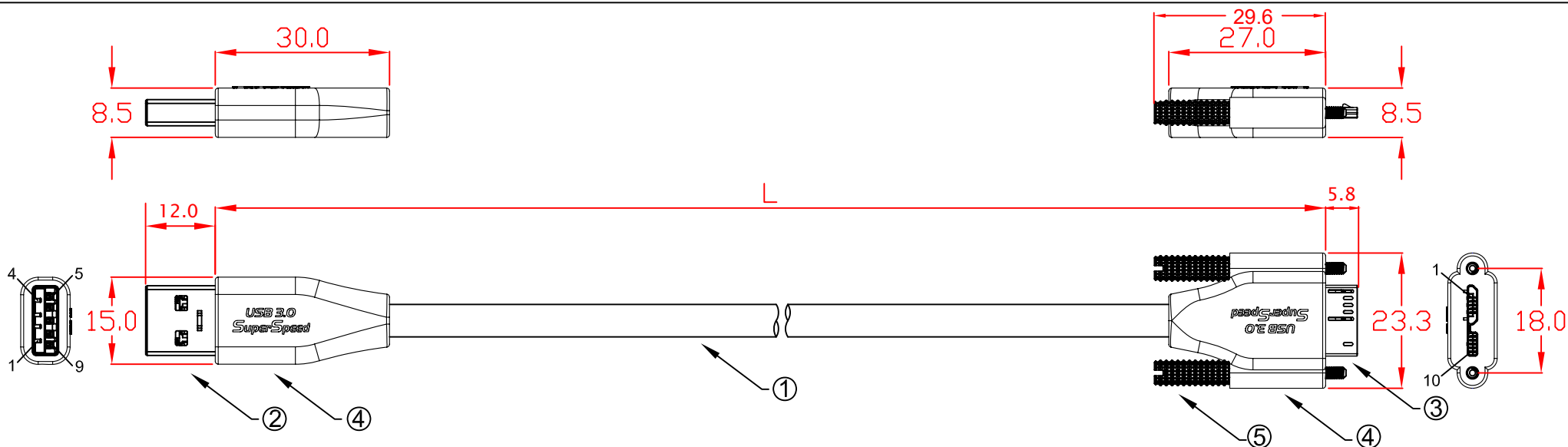

Operating Temperature: 0°C~70°C
 Operating Humidity: 20%~80% (no condensation)
 Storage Temperature: -25°C~85°C
 Storage Humidity: 20%~80% (no condensation)

L:
 CBL-PD302MBSWB-4m 4000mm±30mm
 CBL-PD302MBSWB-5m 5000mm±30mm
 CBL-PD302MBSWB-6m 6000mm±30mm
 CBL-PD302MBSWB-7m 7000mm±30mm

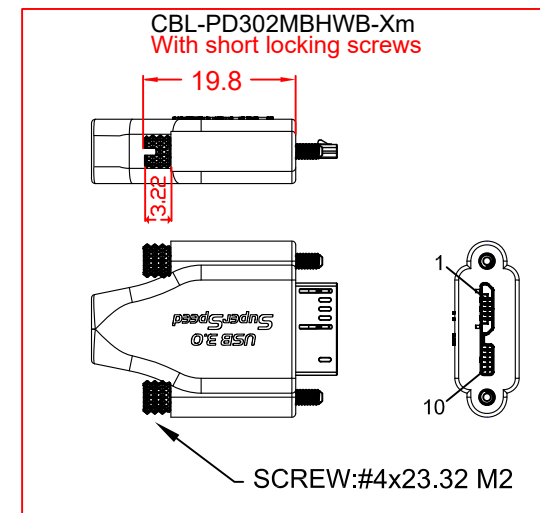
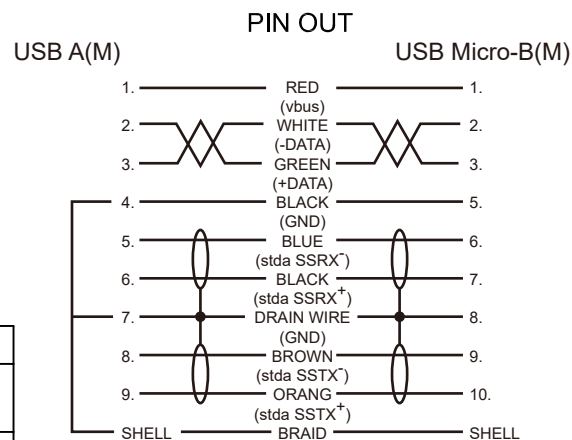

No	MATERIALS LIST:
1.	CABLE:UL2725 (28AWG*1PR+D+AM)x2C+28AWG*1PR+24AWG*1C+AM+B OD:5.6mm PVC JACKET COLOR:BLACK
2.	CONNECTOR:USB 3.0 A/M, 9P, BLUE INSULATOR SOLDER TYPE, NICKEL PLATED SHELL
3.	CONNECTOR:USB 3.0 MicroB/M, 10P, BLACK INSULATOR SOLDER TYPE, NICKEL PLATED SHELL
4.	PVC MOLDED HOUSING, BLACK COLOR
5.	SCREW:#4x33 M2

Jargy part no.	Client part no.	Approved	SCALE	UNIT
CBL-PD302MBS-Xm				mm
Drawing Name		Drawn	Date	REV.
USB 3.0 A to MicroB Cable M/M				1.0

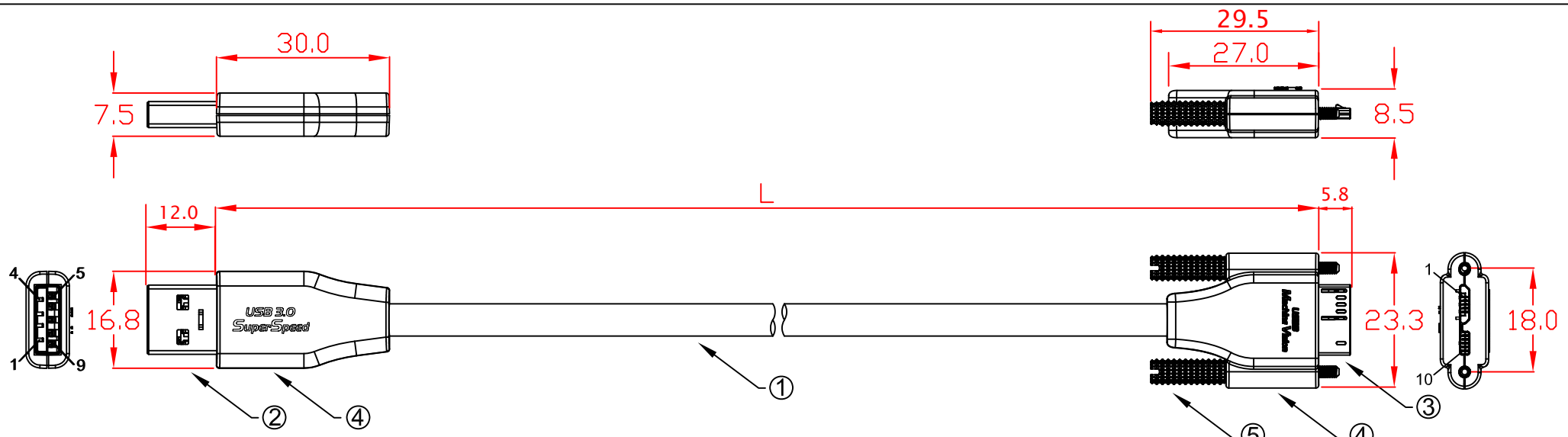

Operating Temperature: 0°C~70°C
 Operating Humidity: 20%~80% (no condensation)
 Storage Temperature: -25°C~85°C
 Storage Humidity: 20%~80% (no condensation)

L:
 CBL-PD302MBSWB-4m 4000mm±30mm
 CBL-PD302MBSWB-5m 5000mm±30mm
 CBL-PD302MBSWB-6m 6000mm±30mm
 CBL-PD302MBSWB-7m 7000mm±30mm

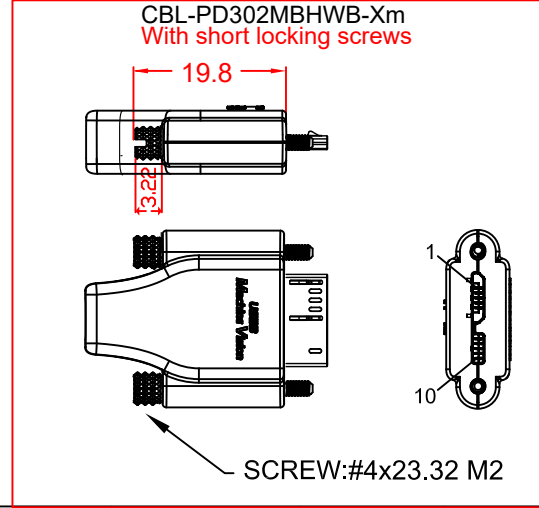
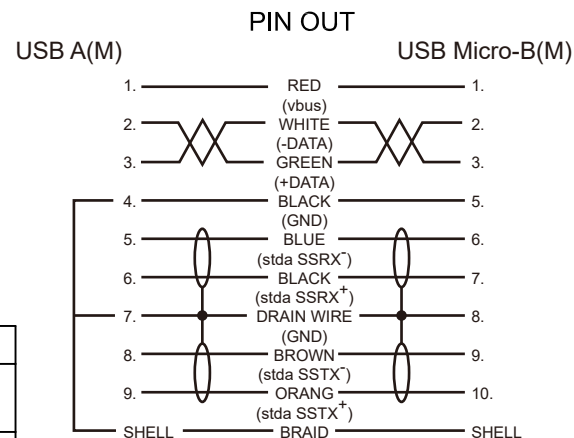

No	MATERIALS LIST:
1.	CABLE:UL2725 (28AWG*1PR+D+AM)x2C+28AWG*1PR+24AWG*1C+AM+B OD:5.6mm PVC JACKET COLOR:BLACK
2.	CONNECTOR:USB 3.0 A/M, 9P, BLUE INSULATOR SOLDER TYPE, NICKEL PLATED SHELL
3.	CONNECTOR:USB 3.0 MicroB/M, 10P, BLACK INSULATOR SOLDER TYPE, NICKEL PLATED SHELL
4.	ABS HOUSING, BLACK COLOR
5.	SCREW:#4x33 M2

Jargy part no.	Client part no.	Approved	SCALE	UNIT
CBL-PD302MBS-Xm				mm
Drawing Name		Drawn	Date	REV.
USB 3.0 A to MicroB Cable M/M				1.0

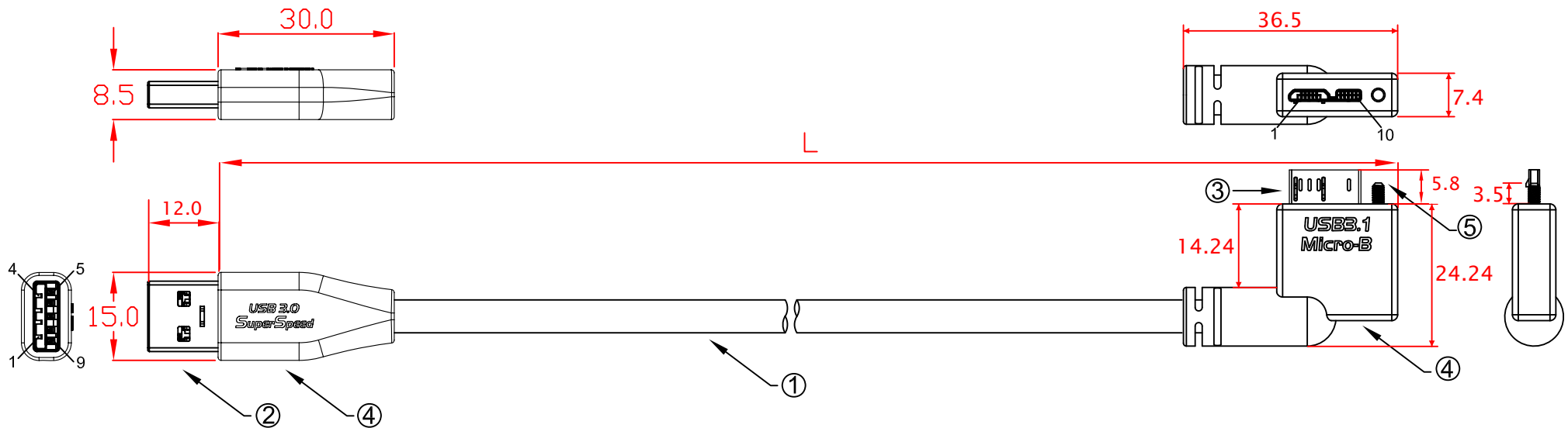

Operating Temperature: 0°C~70°C
 Operating Humidity: 20%~80% (no condensation)
 Storage Temperature: -25°C~85°C
 Storage Humidity: 20%~80% (no condensation)

L:
 CBL-PD302MBHMWB-4mLA 4000mm±30mm
 CBL-PD302MBHMWB-5mLA 5000mm±30mm
 CBL-PD302MBHMWB-6mLA 6000mm±30mm
 CBL-PD302MBHMWB-7mLA 7000mm±30mm

No	MATERIALS LIST:
1.	CABLE:UL2725 (28AWG*1PR+D+AM)x2C+28AWG*1PR+24AWG*1C+AM+B OD:5.6mm PVC JACKET COLOR:BLACK
2.	CONNECTOR:USB 3.0 A/M, 9P, BLUE INSULATOR SOLDER TYPE, NICKEL PLATED SHELL
3.	CONNECTOR:USB 3.0 MicroB/M, 10P, BLACK INSULATOR SOLDER TYPE, NICKEL PLATED SHELL
4.	PVC MOLDED HOUSING, BLACK COLOR
5.	SCREW:#4x23.32 M2
6.	

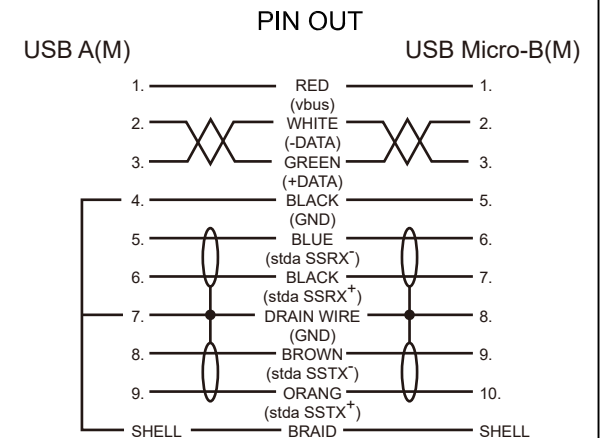

Jargy part no.	Client part no.	Approved	SCALE	UNIT
CBL-PD302MBHMWB-xmlA				mm
Drawing Name		Drawn	Date	REV.
USB 3.0 A to MicroB Cable M/M				1.0

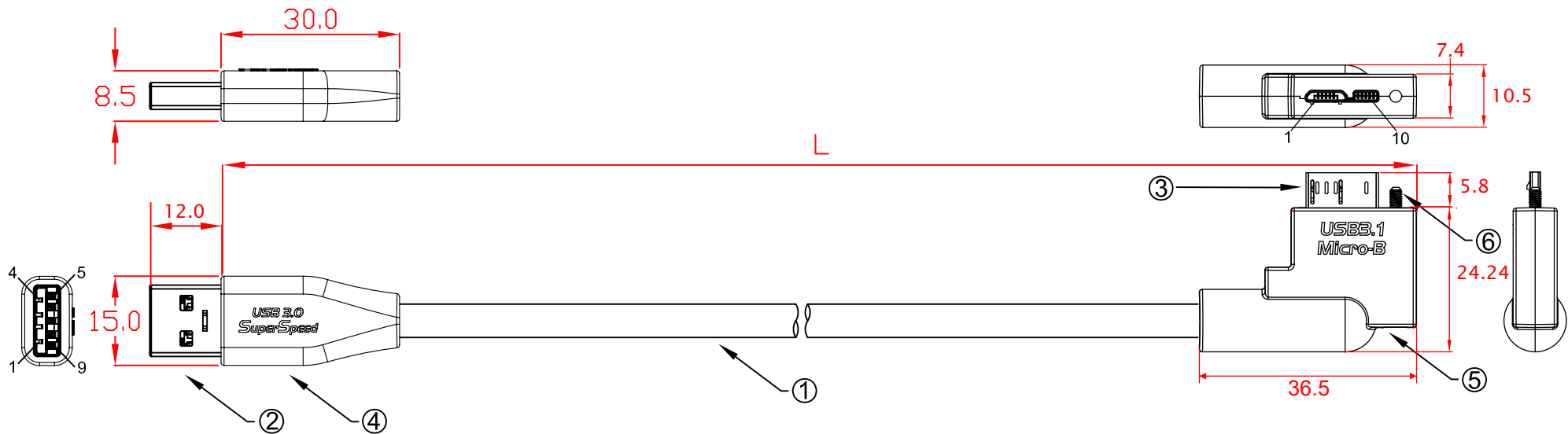

Operating Temperature: 0°C~70°C
 Operating Humidity: 20%~80% (no condensation)
 Storage Temperature: -25°C~85°C
 Storage Humidity: 20%~80% (no condensation)

L:
 CBL-PD302MBSNWB-4mLA 4000mm±30mm
 CBL-PD302MBSNWB-5mLA 5000mm±30mm
 CBL-PD302MBSNWB-6mLA 6000mm±30mm
 CBL-PD302MBSNWB-7mLA 7000mm±30mm

No	MATERIALS LIST:
1.	CABLE:UL2725 (28AWG*1PR+D+AM)x2C+28AWG*1PR+24AWG*1C+AM+B OD:5.6mm PVC JACKET COLOR:BLACK
2.	CONNECTOR:USB 3.0 A/M, 9P, BLUE INSULATOR SOLDER TYPE, NICKEL PLATED SHELL
3.	CONNECTOR:USB 3.0 MicroB/M, 10P, BLACK INSULATOR SOLDER TYPE, NICKEL PLATED SHELL
4.	PVC MOLDED HOUSING, BLACK COLOR
5.	ABS ASSEMBLY HOUSING, BLACK COLOR
6.	SCREW:#4x23.32 M2

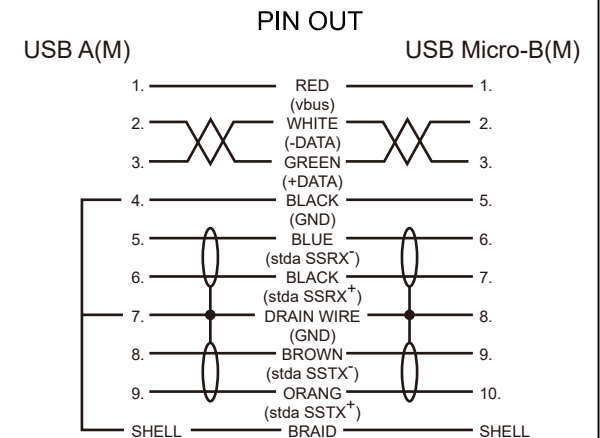

Jargy part no.	Client part no.	Approved	SCALE	UNIT
CBL-PD302MBSNWB-xmLA				mm
Drawing Name		Drawn	Date	REV.
USB 3.0 A to MicroB Cable M/M				1.0

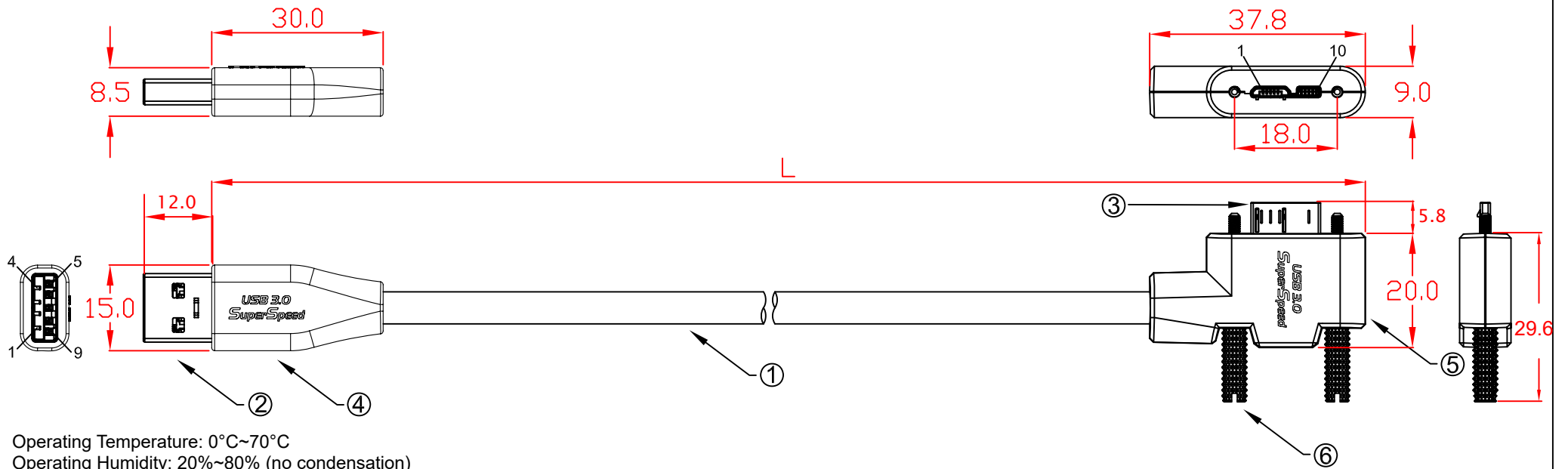

Operating Temperature: 0°C~70°C
 Operating Humidity: 20%~80% (no condensation)
 Storage Temperature: -25°C~85°C
 Storage Humidity: 20%~80% (no condensation)

L:
 CBL-PD302MBSWB-4mLA 4000mm±30mm
 CBL-PD302MBSWB-5mLA 5000mm±30mm
 CBL-PD302MBSWB-6mLA 6000mm±30mm
 CBL-PD302MBSWB-7mLA 7000mm±30mm

No	MATERIALS LIST:
1.	CABLE:UL2725 (28AWG*1PR+D+AM)x2C+28AWG*1PR+24AWG*1C+AM+B OD:5.6mm PVC JACKET COLOR:BLACK
2.	CONNECTOR:USB 3.0 A/M, 9P, BLUE INSULATOR SOLDER TYPE, NICKEL PLATED SHELL
3.	CONNECTOR:USB 3.0 MicroB/M, 10P, BLACK INSULATOR SOLDER TYPE, NICKEL PLATED SHELL
4.	PVC MOLDED HOUSING, BLACK COLOR
5.	ABS ASSEMBLY HOUSING, BLACK COLOR
6.	SCREW:#4x33 M2

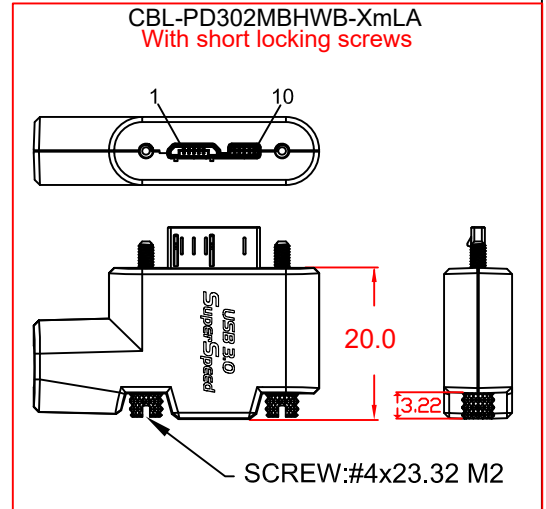
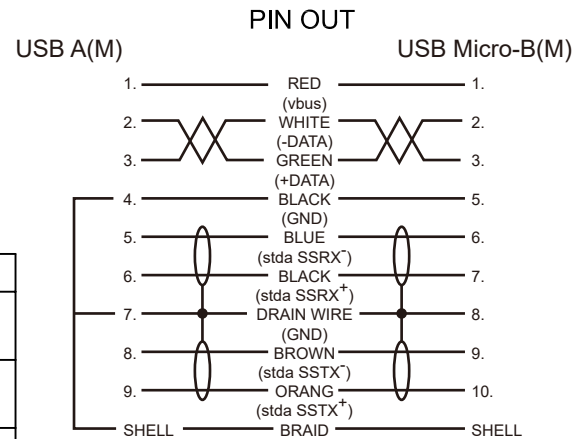

Jargy part no.	Client part no.	Approved	SCALE	UNIT
CBL-PD302MBSWB-XmLA				mm
Drawing Name		Drawn	Date	REV.
USB 3.0 A to MicroB Cable M/M				1.0

Mobile Computing JARGY

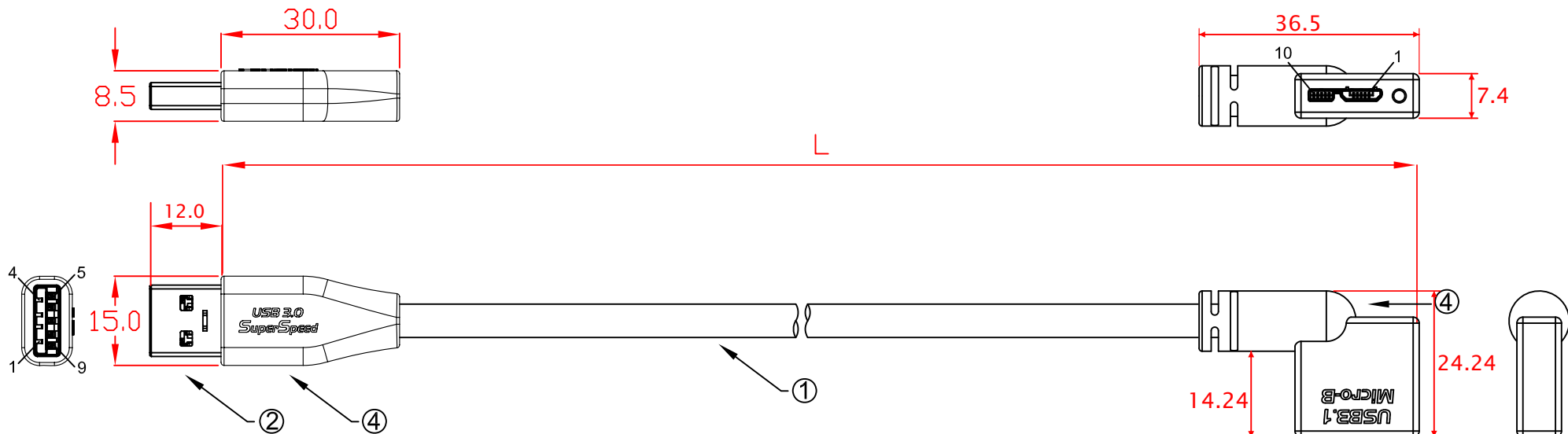

Operating Temperature: 0°C~70°C
 Operating Humidity: 20%~80% (no condensation)
 Storage Temperature: -25°C~85°C
 Storage Humidity: 20%~80% (no condensation)

L:
 CBL-PD302MBHMWB-4mRA 4000mm±30mm
 CBL-PD302MBHMWB-5mRA 5000mm±30mm
 CBL-PD302MBHMWB-6mRA 6000mm±30mm
 CBL-PD302MBHMWB-7mRA 7000mm±30mm

No	MATERIALS LIST:
1.	CABLE:UL2725 (28AWG*1PR+D+AM)x2C+28AWG*1PR+24AWG*1C+AM+B OD:5.6mm PVC JACKET COLOR:BLACK
2.	CONNECTOR:USB 3.0 A/M, 9P, BLUE INSULATOR SOLDER TYPE, NICKEL PLATED SHELL
3.	CONNECTOR:USB 3.0 MicroB/M, 10P, BLACK INSULATOR SOLDER TYPE, NICKEL PLATED SHELL
4.	PVC MOLDED HOUSING, BLACK COLOR
5.	SCREW:#4x23.32 M2
6.	

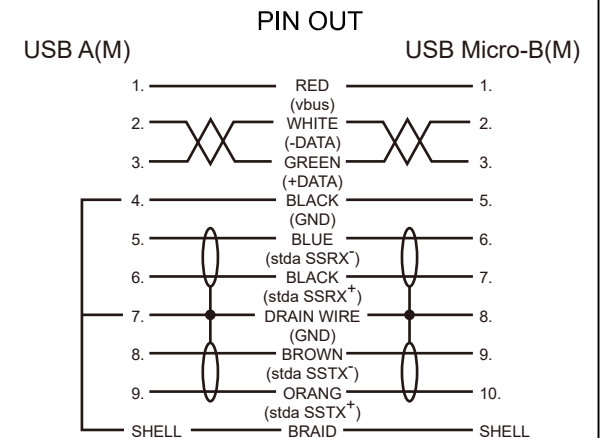

Jargy part no.	Client part no.	Approved	SCALE	UNIT
CBL-PD302MBHMWB-xmRA				mm
Drawing Name		Drawn	Date	REV.
USB 3.0 A to MicroB Cable M/M				1.0

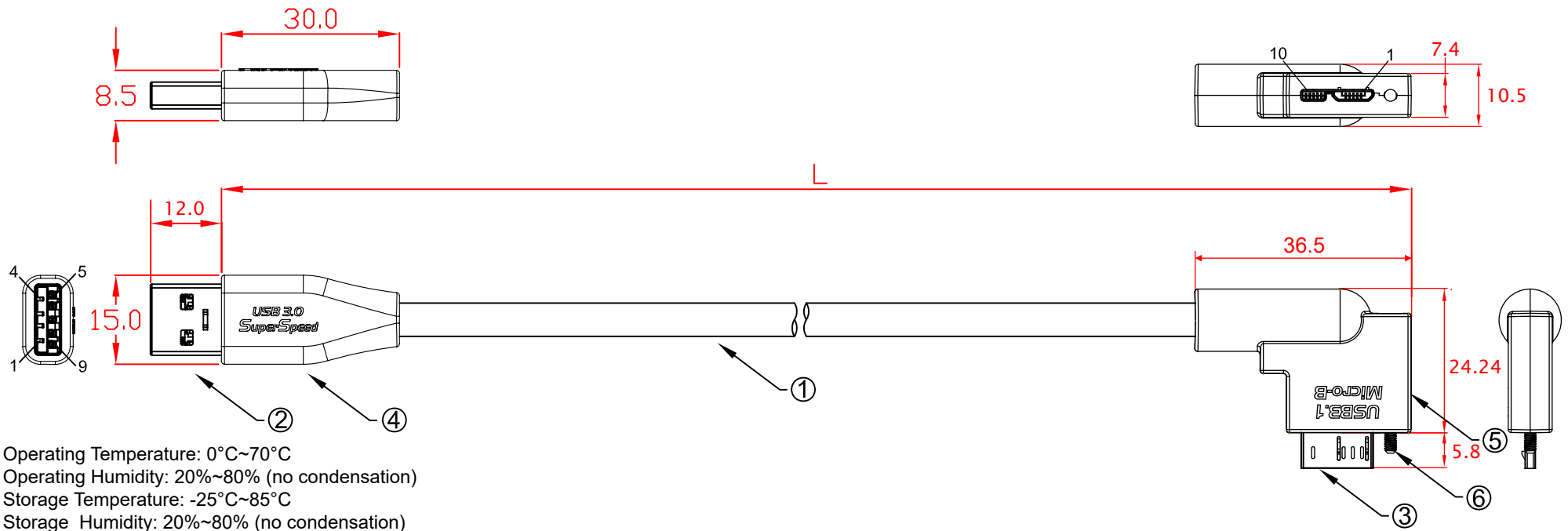

Operating Temperature: 0°C~70°C
 Operating Humidity: 20%~80% (no condensation)
 Storage Temperature: -25°C~85°C
 Storage Humidity: 20%~80% (no condensation)

L:
 CBL-PD302MBSNWB-4mRA 4000mm±30mm
 CBL-PD302MBSNWB-5mRA 5000mm±30mm
 CBL-PD302MBSNWB-6mRA 6000mm±30mm
 CBL-PD302MBSNWB-7mRA 7000mm±30mm

No	MATERIALS LIST:
1.	CABLE:UL2725 (28AWG*1PR+D+AM)x2C+28AWG*1PR+24AWG*1C+AM+B OD:5.6mm PVC JACKET COLOR:BLACK
2.	CONNECTOR:USB 3.0 A/M, 9P, BLUE INSULATOR SOLDER TYPE, NICKEL PLATED SHELL
3.	CONNECTOR:USB 3.0 MicroB/M, 10P, BLACK INSULATOR SOLDER TYPE, NICKEL PLATED SHELL
4.	PVC MOLDED HOUSING, BLACK COLOR
5.	ABS ASSEMBLY HOUSING, BLACK COLOR
6.	SCREW:#4x23.32 M2

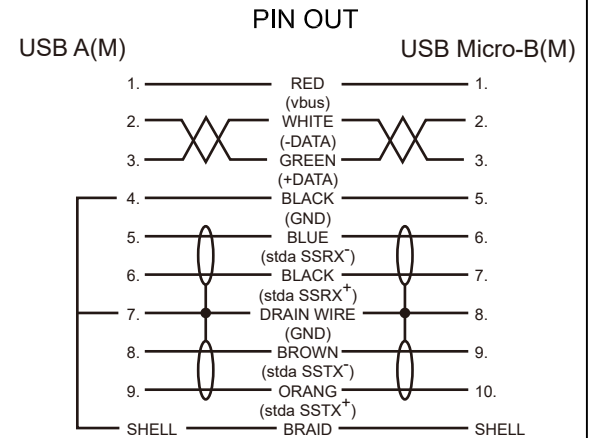

Jargy part no.	Client part no.	Approved	SCALE	UNIT
CBL-PD302MBSNWB-xmRA				mm
Drawing Name		Drawn	Date	REV.
USB 3.0 A to MicroB Cable M/M				1.0

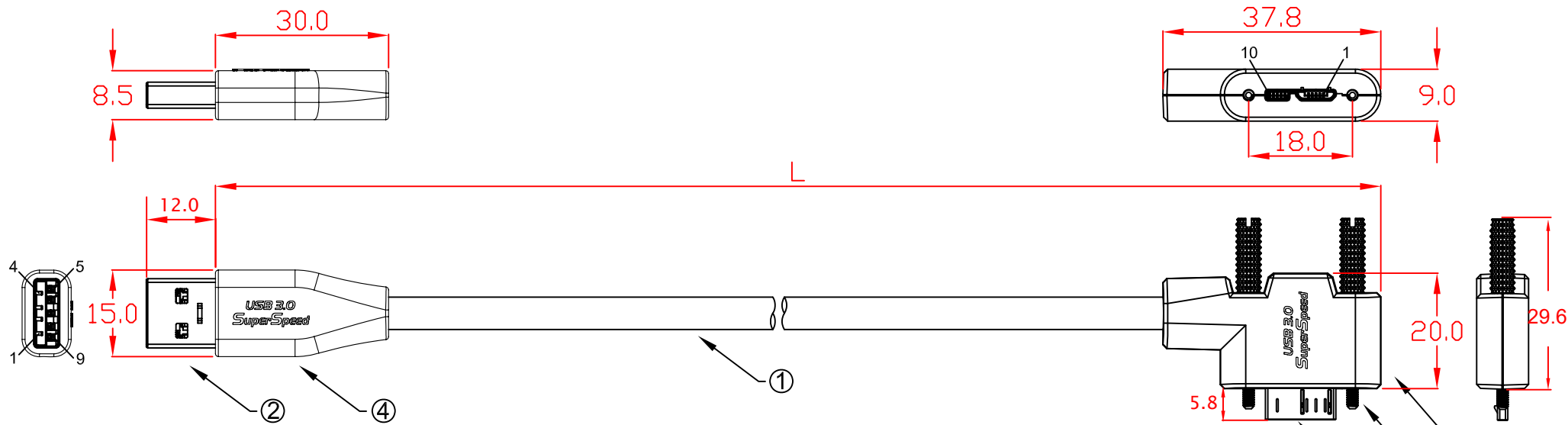

Operating Temperature: 0°C~70°C
 Operating Humidity: 20%~80% (no condensation)
 Storage Temperature: -25°C~85°C
 Storage Humidity: 20%~80% (no condensation)

L:
 CBL-PD302MBSWB-4mRA 4000mm±30mm
 CBL-PD302MBSWB-5mRA 5000mm±30mm
 CBL-PD302MBSWB-6mRA 6000mm±30mm
 CBL-PD302MBSWB-7mRA 7000mm±30mm

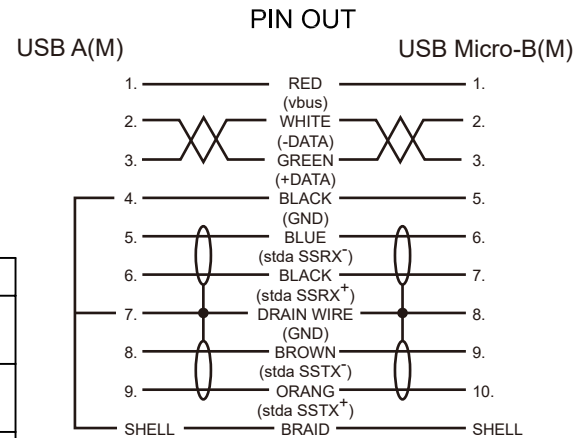
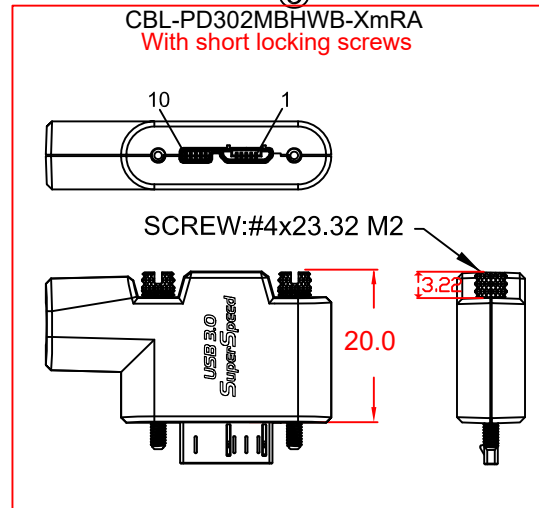

No	MATERIALS LIST:
1.	CABLE:UL2725 (28AWG*1PR+D+AM)x2C+28AWG*1PR+24AWG*1C+AM+B OD:5.6mm PVC JACKET COLOR:BLACK
2.	CONNECTOR:USB 3.0 A/M, 9P, BLUE INSULATOR SOLDER TYPE, NICKEL PLATED SHELL
3.	CONNECTOR:USB 3.0 MicroB/M, 10P, BLACK INSULATOR SOLDER TYPE, NICKEL PLATED SHELL
4.	PVC MOLDED HOUSING, BLACK COLOR
5.	ABS ASSEMBLY HOUSING, BLACK COLOR
6.	SCREW:#4x33 M2

Jargy part no.	Client part no.	Approved	SCALE	UNIT
CBL-PD302MBSWB-XmRA				mm
Drawing Name		Drawn	Date	REV.
USB 3.0 A to MicroB Cable M/M				1.0

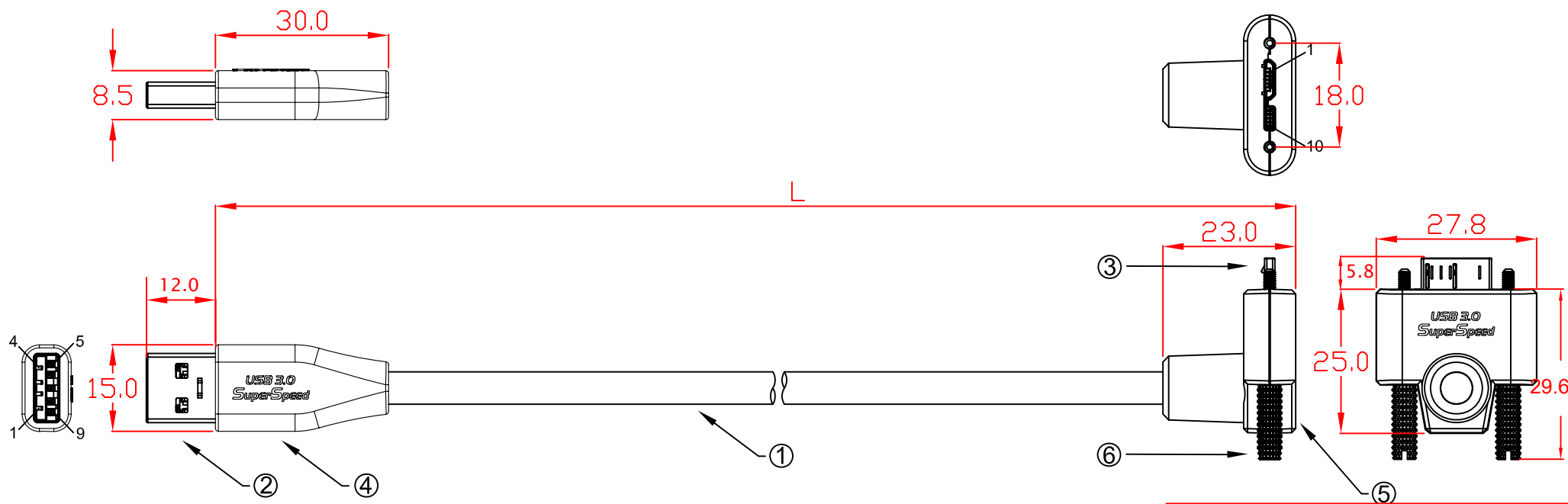

Operating Temperature: 0°C~70°C
 Operating Humidity: 20%~80% (no condensation)
 Storage Temperature: -25°C~85°C
 Storage Humidity: 20%~80% (no condensation)

L:
 CBL-PD302MBSWB-4mUA 4000mm±30mm
 CBL-PD302MBSWB-5mUA 5000mm±30mm
 CBL-PD302MBSWB-6mUA 6000mm±30mm
 CBL-PD302MBSWB-7mUA 7000mm±30mm

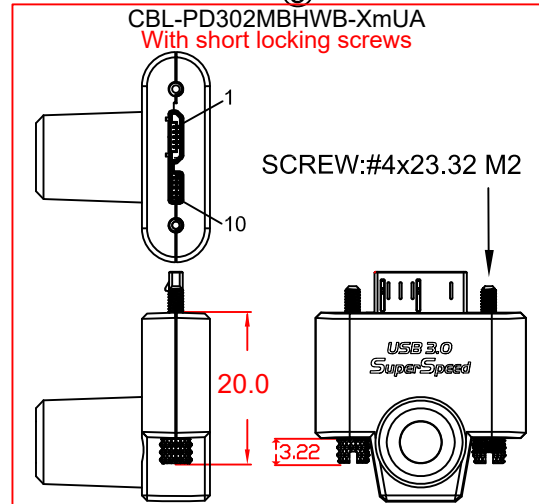
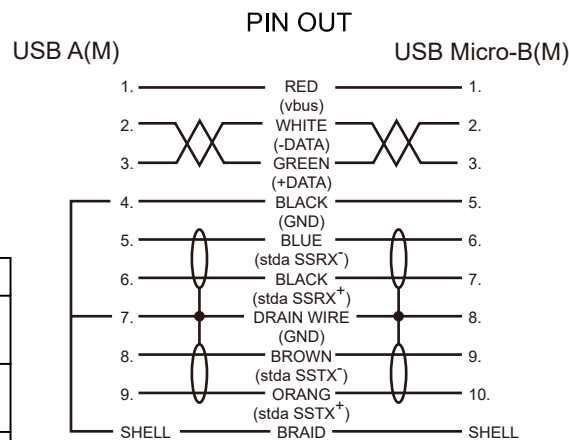

No	MATERIALS LIST:
1.	CABLE:UL2725 (28AWG*1PR+D+AM)x2C+28AWG*1PR+24AWG*1C+AM+B OD:5.6mm PVC JACKET COLOR:BLACK
2.	CONNECTOR:USB 3.0 A/M, 9P, BLUE INSULATOR SOLDER TYPE, NICKEL PLATED SHELL
3.	CONNECTOR:USB 3.0 MicroB/M, 10P, BLACK INSULATOR SOLDER TYPE, NICKEL PLATED SHELL
4.	PVC MOLDED HOUSING, BLACK COLOR
5.	ABS ASSEMBLY HOUSING, BLACK COLOR
6.	SCREW:#4x33 M2

Jargy part no.	Client part no.	Approved	SCALE	UNIT
CBL-PD302MBSWB-XmUA				mm
Drawing Name		Drawn	Date	REV.
USB 3.0 A to MicroB Cable M/M				1.0

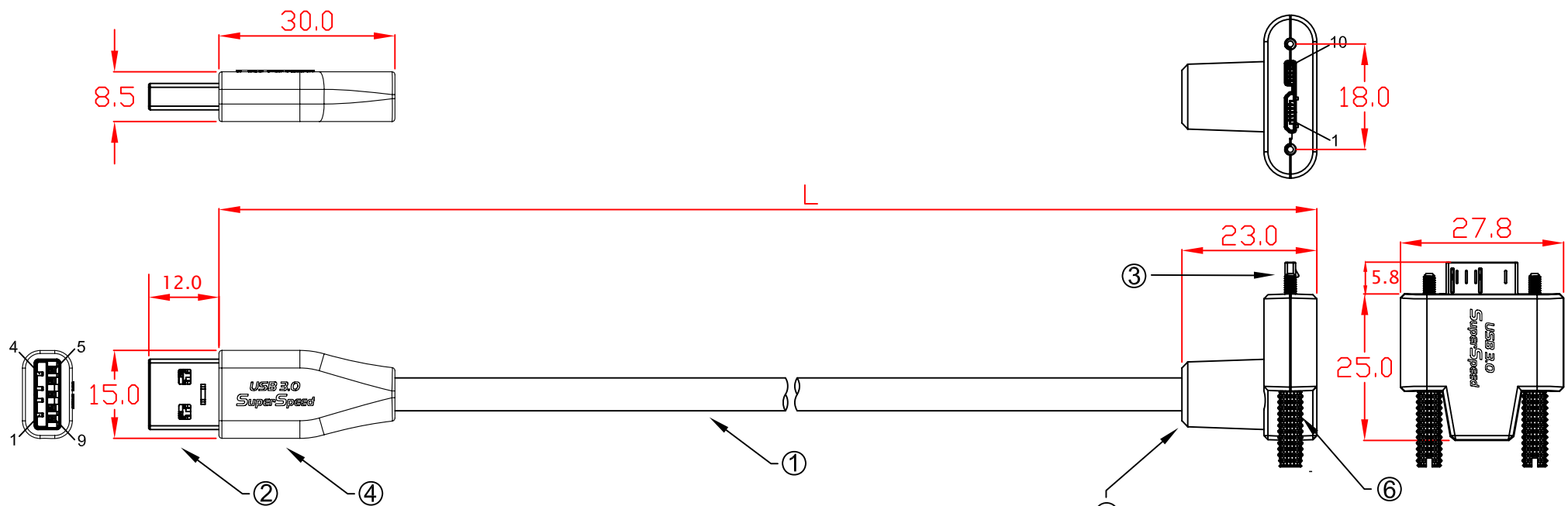

Operating Temperature: 0°C~70°C
 Operating Humidity: 20%~80% (no condensation)
 Storage Temperature: -25°C~85°C
 Storage Humidity: 20%~80% (no condensation)

- L.
- CBL-PD302MBSWB-4mDA 4000mm±30mm
 - CBL-PD302MBSWB-5mDA 5000mm±30mm
 - CBL-PD302MBSWB-6mDA 6000mm±30mm
 - CBL-PD302MBSWB-7mDA 7000mm±30mm

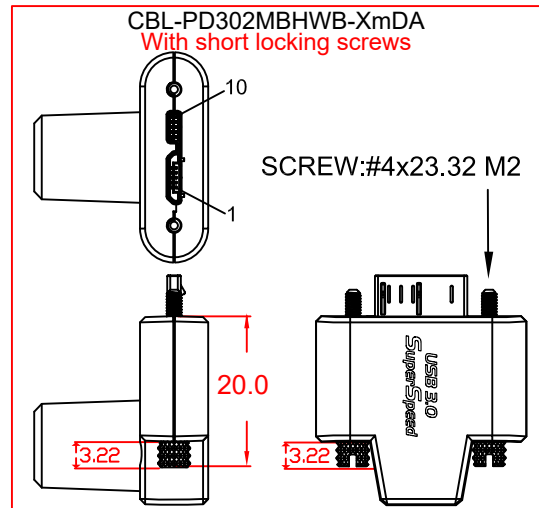
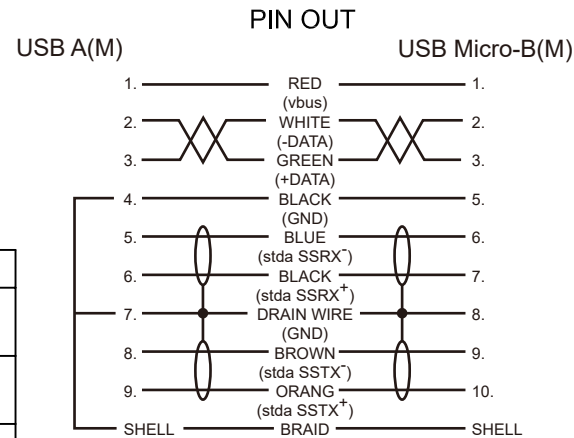

No	MATERIALS LIST:
1.	CABLE:UL2725 (28AWG*1PR+D+AM)x2C+28AWG*1PR+24AWG*1C+AM+B OD:5.6mm PVC JACKET COLOR:BLACK
2.	CONNECTOR:USB 3.0 A/M, 9P, BLUE INSULATOR SOLDER TYPE, NICKEL PLATED SHELL
3.	CONNECTOR:USB 3.0 MicroB/M, 10P, BLACK INSULATOR SOLDER TYPE, NICKEL PLATED SHELL
4.	PVC MOLDED HOUSING, BLACK COLOR
5.	ABS ASSEMBLY HOUSING, BLACK COLOR
6.	SCREW:#4x33 M2

Jargy part no.	Client part no.	Approved	SCALE	UNIT
CBL-PD302MBSWB-XmDA				mm
Drawing Name		Drawn	Date	REV.
USB 3.0 A to MicroB Cable M/M				1.0